

**Document ID: 4163680**

# Passenger Compartment Screen Air Deflector Kit Installation

**Installation Instructions Part Number**

23353690

**Kit Contents**

<b>Qty</b>	<b>Description</b>
1	Deflector Screen
1	LH - Bracket
1	RH - Bracket
6	Isolators
4	Spacers
4	Washers
4	M6 Bolts
1	LH - Mylar Template
1	RH - Mylar Template
1	Installation Instructions

**Tools Required**

- Ratchet
- Torque Wrench
- Center Punch
- Power Drill
- Clean Cloth

© 2018 General Motors. All rights reserved.

- Masking Tape
- Socket (8mm)
- Torx Socket (t-30)
- Drill Bit (1/8")
- Drill Bit (5/16")
- 50/50 Alcohol/Water Solution

**Important:** PROLONGED DRIVING AT EXCESSIVE SPEED MAY CAUSE DAMAGE TO PART.

## Procedure

### **Vehicle Preparation**

1. Temperature must be between 61° F-86° F (16° C-31° C).
2. Wash and thoroughly dry vehicle's tonneau cover.
3. For best results, the tonneau cover and the tonneau cover 'speed-bumps' should be free of damage (dents, scuffs, creases, fractures, etc).
4. Do not use petroleum based cleaning products. If a strong cleaner is required, we recommend using 3M general purpose Adhesive Cleaner (P/N 08984) with a clean cloth to remove all visible contaminants (road tar, etc). It may take the use of several cloths to obtain a clean surface. It is important to replace the cloth when soiled or you will be smearing or wiping contaminants back on the vehicle. After using the Adhesive Cleaner, use the SOLVENT PKG-BODY SURF CLNR;(P/N 12365938 14W 0849Z 0030).

### **Deflector Screen Installation**

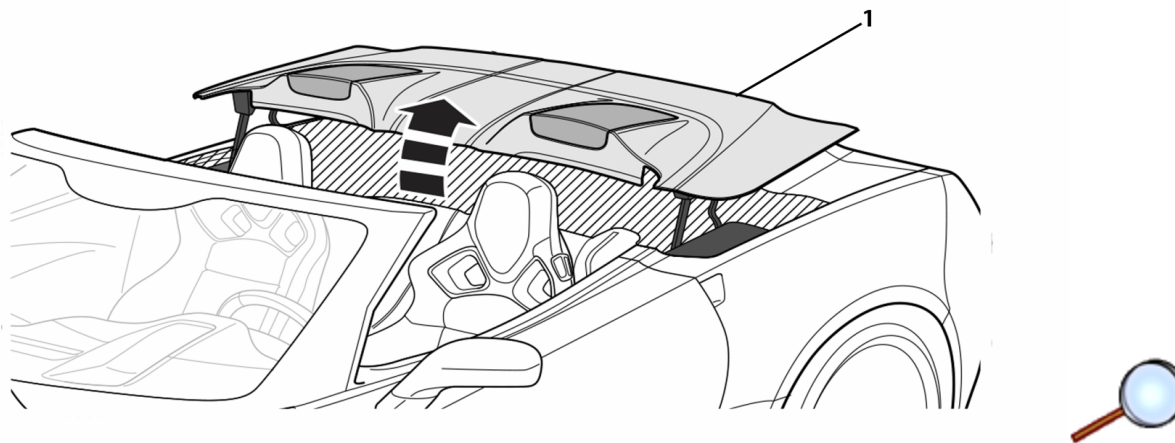

1. Raise the vehicle's tonneau cover (1) into the 'UP' position. This will allow access to the underside of the tonneau cover.

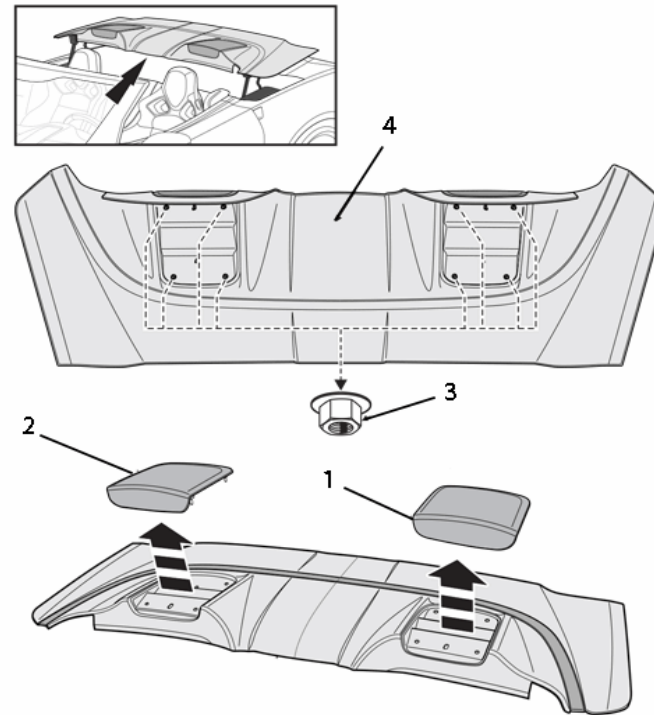

2. Disassemble the LH (1) & RH (2) Tonneau Inserts by using an 8mm socket to remove the 8x M5 nuts (3) (4x nuts per side) that are holding the Tonneau Inserts to the tonneau cover (4). Keep the 8x M5 nuts to be re-installed later.

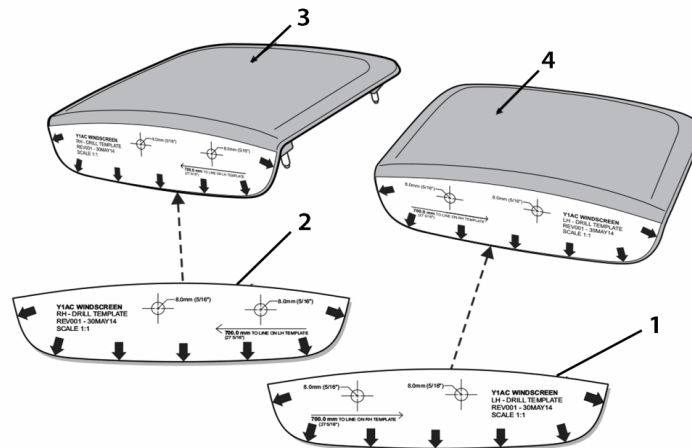

3. With the LH (4) & RH (3) Tonneau Inserts off the car, align the LH Mylar Template (1) to the LH and secure with masking tape.  
4. Repeat Step #3 on the RH Tonneau Insert (3) and the RH Mylar Template (2).

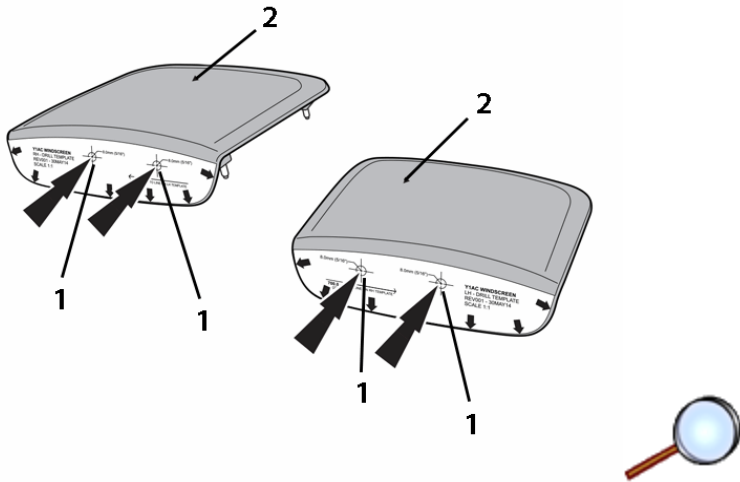

5. Center punch all indicated hole locations (1). 2x locations per template.
6. Drill each center punched location (1) with a 1/8" drill bit. 2x locations per tonneau insert (2).
7. Enlarge each 1/8" hole with a 5/16" drill bit. 2x locations per tonneau insert (2).

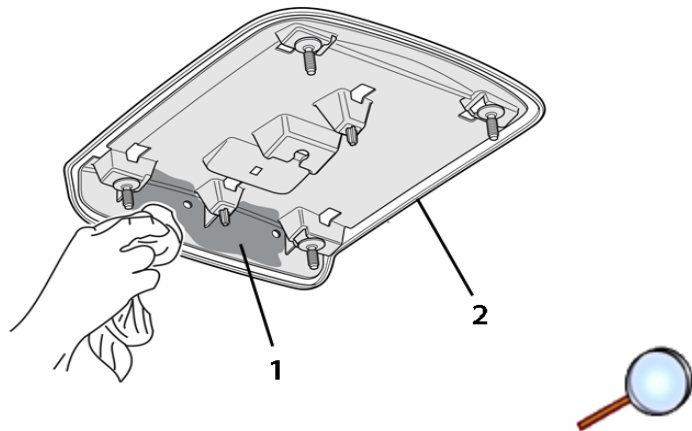
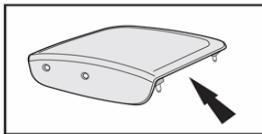

8. Remove the Mylar Templates from the Tonneau inserts.
9. Use 50/50 Alcohol/Water Solution to clean the back side (1) of the LH Tonneau Insert (2).

10. Repeat step #9 on the back side of the RH Tonneau Insert.

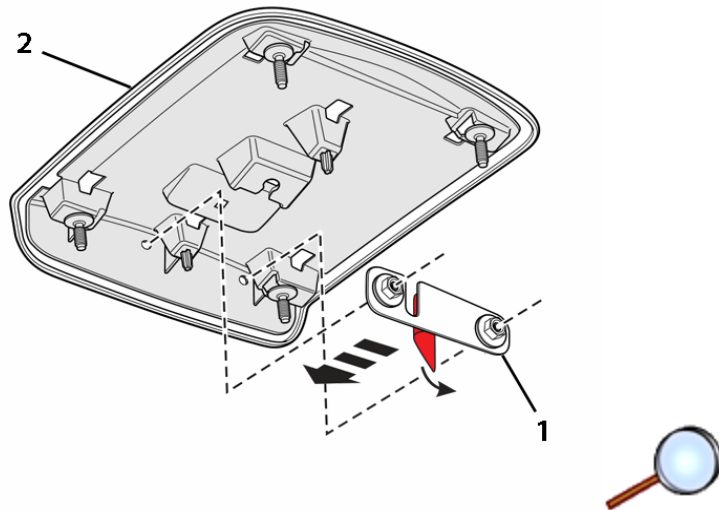

11. Peel the protective liner off of the adhesive tape on the back side of the LH Bracket. Align the holes of the LH Bracket (1) with the holes drilled into the back side of the LH Tonneau Insert (2). Secure the LH Bracket to the back side of the LH Tonneau Insert using the adhesive tape.

12. Repeat step #11 with the RH Bracket and RH Tonneau Insert

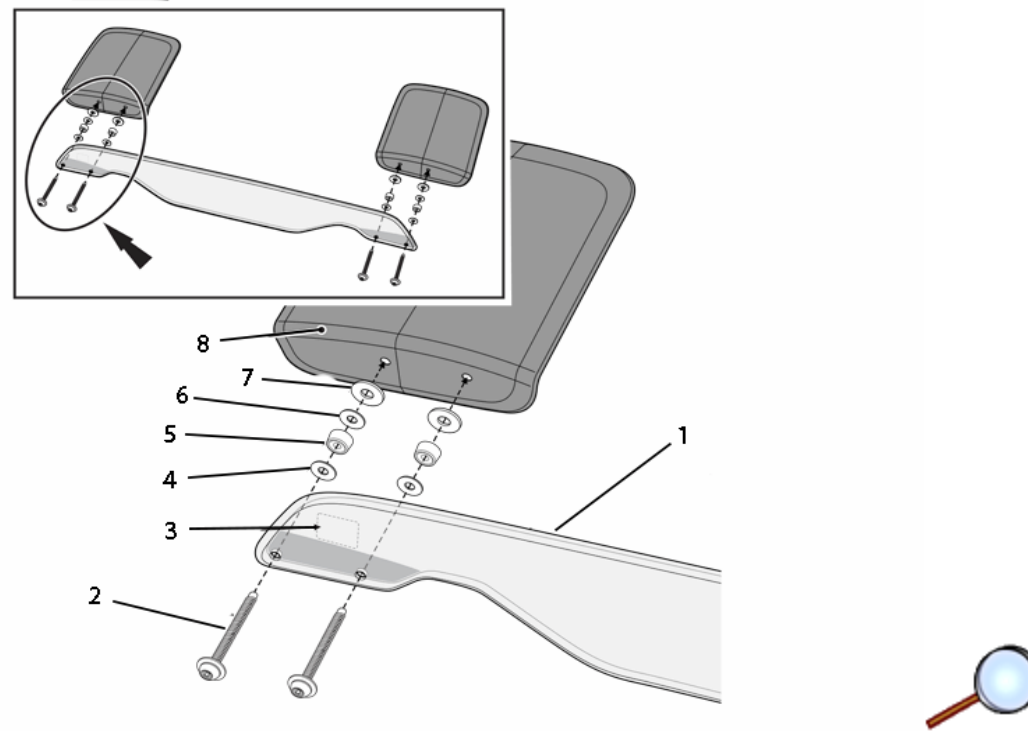

13. Starting on the RH side, align the holes on the front face of the RH Tonneau Insert (8) with the RH mounting holes on the rear side of the Deflector Screen (1). Assemble the two parts together using the provided fasteners, M6 bolt (2), isolator (4), spacer (5), isolator (6), washer (7) but **DO NOT TIGHTEN**. **ATTENTION:** Ensure all fasteners are in the correct order. **ATTENTION:** Ensure the orientation of the Deflector Screen is correct. The side of the Deflector Screen with the GM 'Regulatory Box' (3) should be attached to the RH Tonneau Insert.

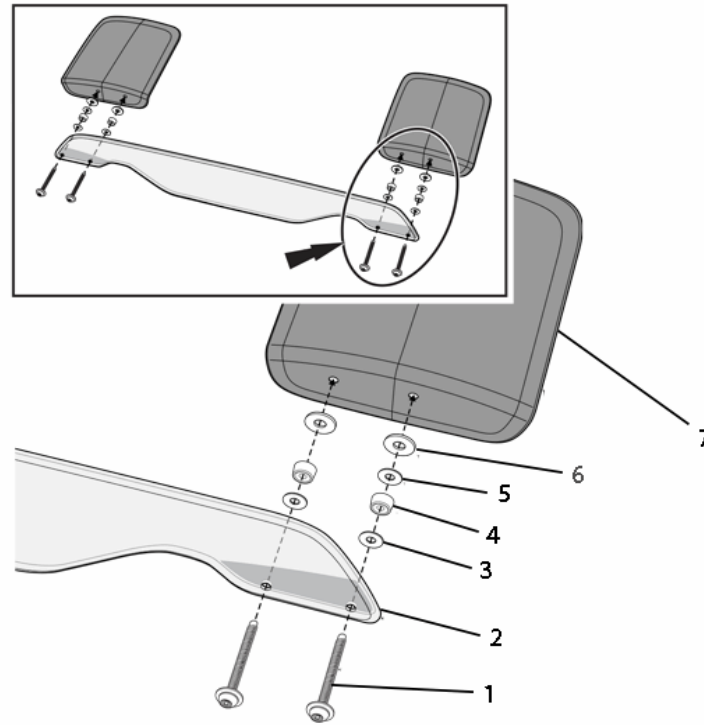

14. Align the holes on the front face of the LH Tonneau Insert (7) with the LH mounting holes on the Deflector Screen (2). Assemble the two parts together using the provided fasteners, M6 bolt (1), isolator (3), spacer (4), isolator (5), washer (6). **DO NOT TIGHTEN. ATTENTION:** Ensure all fasteners are in the correct order.

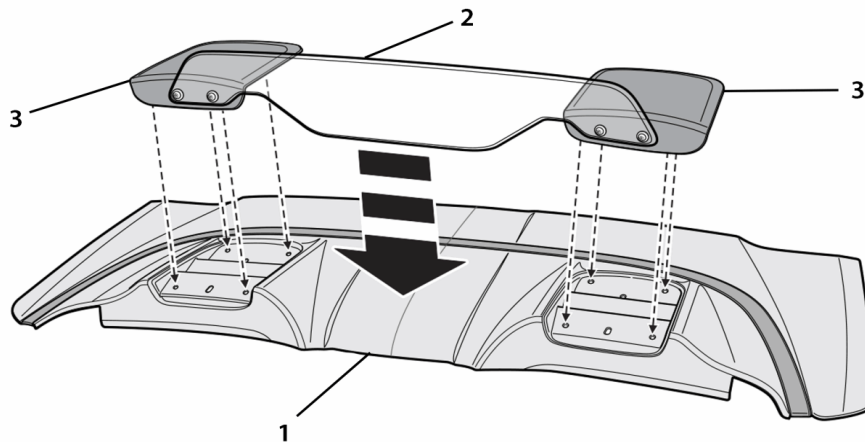

15. Carefully lower the Deflector Screen Assembly (2) onto the vehicle's tonneau cover (1). Align the mounting of the LH & RH Tonneau Inserts (3) with the original mounting on the tonneau cover.

**Caution:** Take care in order not to scratch the vehicle's paint with the exposed studs and/or edges of the assembly.

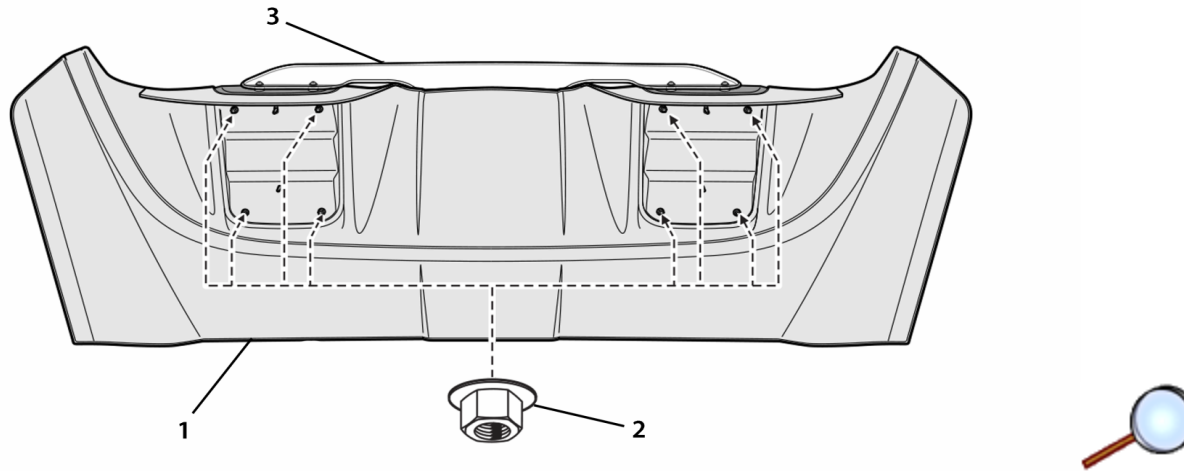

16. Re-install 8x M5 nuts (2) removed in Step #2.

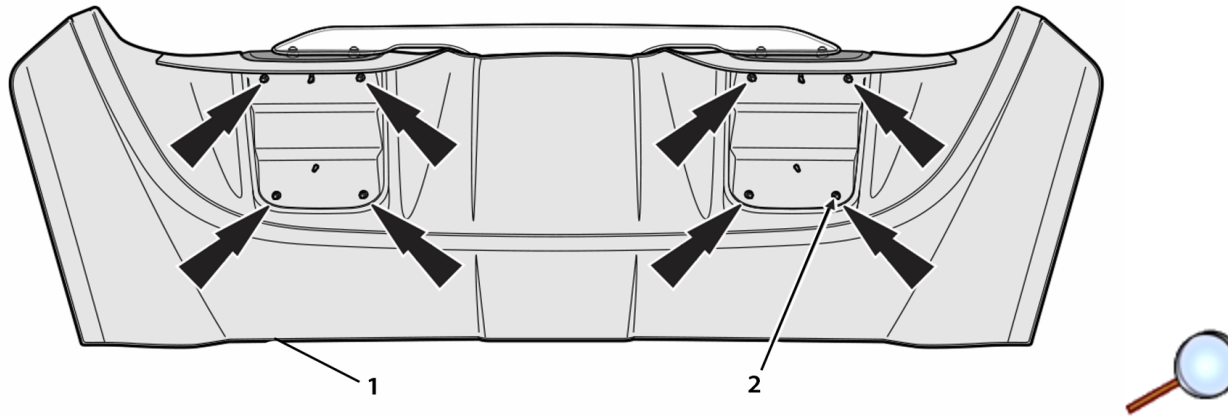

17. Confirm that the LH & RH Tonneau Inserts/Deflector Screen Assembly are properly aligned onto the tonneau cover (1) and then tighten the 8x M5 Nuts (2) to 4.7N.m +/- 0.9N.m.



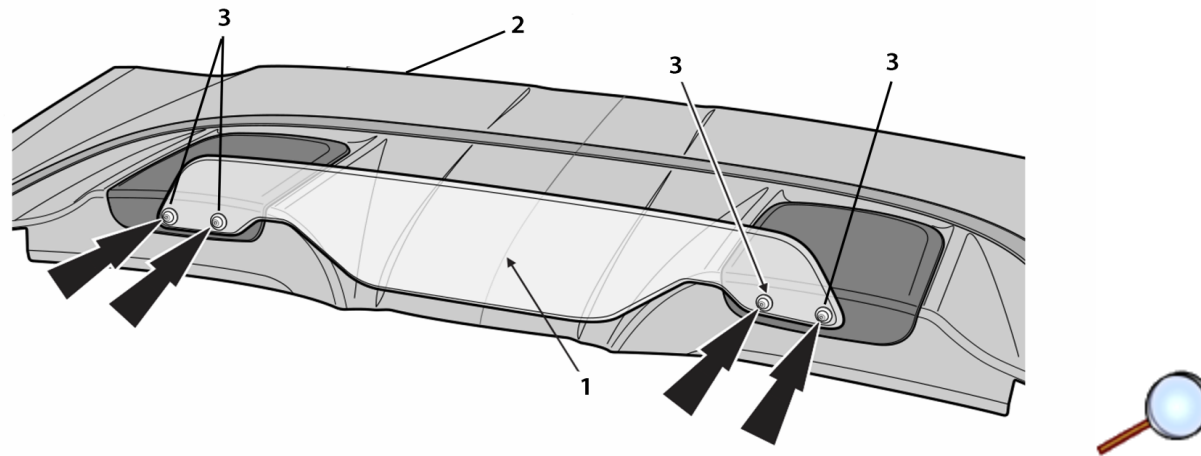

18. Using a T-30 TORX drive socket, tighten the 4x M6 Bolts (3) that secure the Deflector Screen (1) to a torque of 7.0N.m +/- 1.0N.m.
19. Lower the tonneau cover (2) into the full closed position. Installation complete.